

## MOD-AI8 Modbus Analogue Input Modules

8-Channel Analog Input Module is used to interface measurement circuits. Each channel can be separately configured to measure resistive sensors, current loops or voltage messages.

Configuration is done using setup jumpers. Analog to digital converter is high precision 20-bit sigma-delta converter, which has better than 110 dB rejection at 50 Hz.

Analog Input module can also be used to interface potential free contacts. All important values are saved to eeprom during power off.

Module address and communication speed is selected using onboard DIP switch.

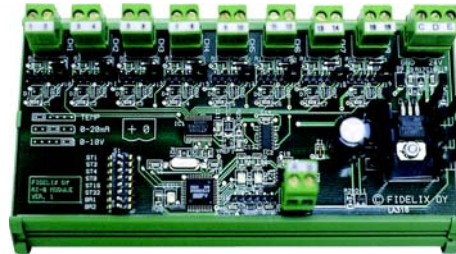

### Features

- 8 Analogue Inputs
- Resistance, Voltage and Current Measurements
- 20-Bit High Resolution A/D-converter
- Plug-in Terminals and DIN-rail Mounting
- RS-485 Communication using Modbus RTU

Model Type	Model	Description
	<b>MOD-AI8</b>	8 Analogue Input Module, Modbus Communications.

Technical Data		
Operating Voltage	20..26Vdc	
Power Consumption	25..40mA	
Communication	Modbus RTU	
Communication Speed	9600 bps, 19200 bps, 38400 bps or 57600 bps	
Address Range	1..63 via bit switch	
Rejection at 50Hz	Better than 110 dB	
Sensor Types	NTC, Pt1000, Ni1000, 0..20mA, 0..10V, 2..10V	
Loop Current for Resitive Sensors	0.5 mA @ 1kOhm, 0.2mA @ 10kOhm	
Operating Temperature	0..50°C	
Dimensions	W160 x H95 x D65 mm	

Wiring Details

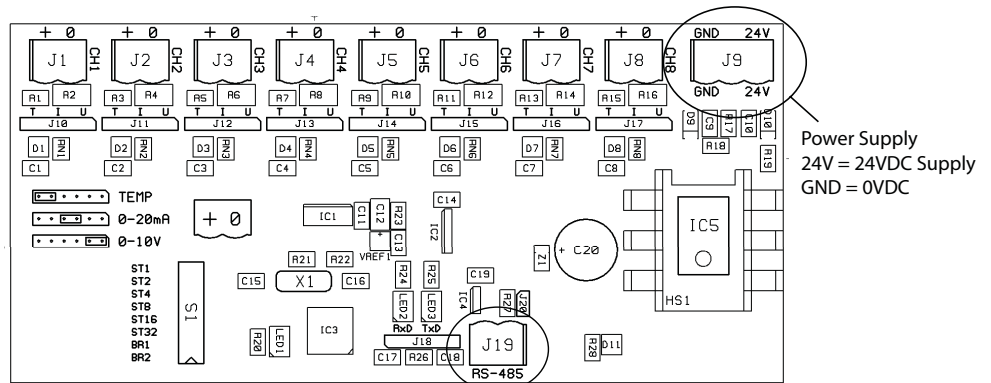

Bit Switch Settings

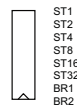

Communication Speed

Speed	BR 1	BR 2
9600bps	Off	Off
19200bps	On	Off
38400bps	Off	On
57600bps	On	On

Modbus Address

Use ST 1 + ... + ST 32 to set the modbus address.  
 e.g.  
 ST 1 only ON = Modbus Slave Address 1  
 ST 4 only ON = Modbus Slave Address 4  
 ST 4 and ST ON = Address 5 (1+4) etc..

Modbus Registers

The MOD-AI8 is a Modbus slave. Via the Modbus communication channel each of the input channels can be read. The MOD-AI8 returns "raw" A/D converter values and these are scaled/filtered in the Modbus master such as FDX BMS outstations.

For further information on the Modbus registers please refer to the *Modbus IO-Module Configuration Guide*.