

KLU-FL Wireless Temperature / Humidity Transmitters

KLU-FL is a wireless transmitter transmitting three signals (temperature, humidity and light level) using 868.30MHz frequency and FSK modulation. Temperature and humidity are measured with the built-in measurement elements. For the light level measurement an external LUX11 sensor is required to be connected to the unit.

KLU-FL is part of the SyxthSense wireless sensor range that caters for any typical building application using the latest RF technology. The products have been designed to operate in a wide range of environments and proven to operate reliably in all situations. KLU-FL wireless sensors have a transmission range of up to 20..100m inside buildings and up to 500m line of sight. The transmission range can be extended with up to 8 repeaters to cater for most applications.



Model Type	Model	Description
	KLU-FL	Wireless Temperature and Humidity Transmitter, Battery Powered
	KLU-FL-24	Wireless Temperature and Humidity transmitter with 12..24Vac/dc Power Supply
Technical Data	Power Supply	KLU-FL: 3.6V AA Lithium Battery 2Ah KLU-FL-24: 12..24Vac/dc
	Battery Life	Transmission every 6 seconds : Up to 1 year Transmission every 1, 5, 15, 30 minutes: Up to 6 years From the beginning of low battery alarm: 3 months
	Frequency	868.30 Mhz
	Modulation	FSK
	Transmission Power	+8 dBm
	Reception Sensitivity	-109 dBm
	Range	Line of sight: Up to 500m In buildings up to 20..100m depending on wall structures Range can be extended up to 8 times with FLREP repeaters
	Measurement Range	Temperature: -50..+150°C Humidity: 0..100%rH (5..95% rH continuous) Light Level: 0..1000 lux (via LUX11)
	Measurement Accuracy	Temperature: +/-0.5°C (at 25°C) Humidity: +/-3% rH (25°C)
	Addressing	Via FLSER Service Tool
	Ambient Humidity	0..100% rH Non-Condensing
	Agency Approvals	Directives 72/23/EEC, 1999/5/EC, 2000/299/EC Standards EN60950, EN300220-2 and EN301480-3
	Cable Gland	M16
	Protection Class	IP54. Cable Gland Downwards

Dimensions W115 x H115 x D45mm

KLU-FL Operation

KLU-FL transmits the measurement signals to the FLTA receiver at the set intervals (from every 6 seconds to every 30 minutes). The setting is configured using a trimmer on the printed circuit board under the cover the unit.

KLU-FL battery lifetime depends on the set transmission interval and varies between 1 to 6 years.

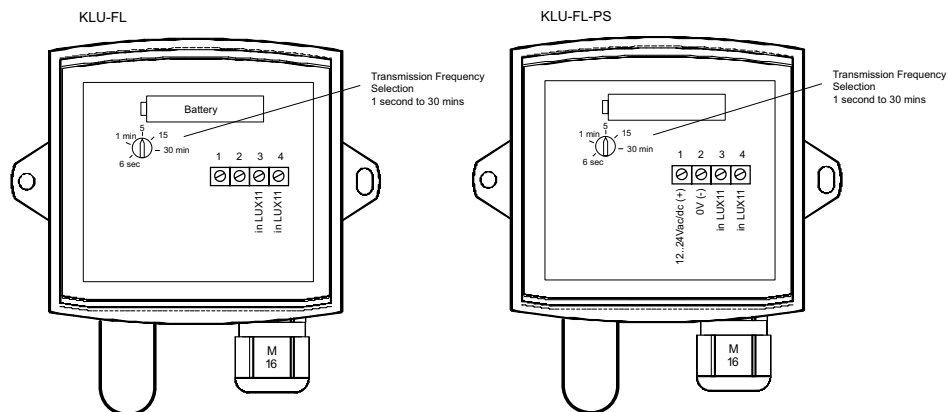

KLU-FL transmits the measurement signals to FLTA receiver/control module either directly or via (multiple) receiver(s). FLTA control module has 8 x 0..10Vdc analogue outputs that can be configured for appropriate units of measurement. FLTA module acts also as a Modbus Communication interface for sensor readings to Modbus masters such as WebBiter web-browser interface and to BMS systems.

The FLTA control module/receiver monitors also the wireless sensors for any malfunctions and for the low battery level. If the battery level is approximately 5% the FLTA indicates on the requirement to change the battery.

Each FLTA control module/receiver can have up to 99 sensors in its operating area. Up to 63 control modules can operate in the same wireless area. Total maximum of 6,237 wireless transmitted can be used in a single area.

FLREP repeaters can be used to extend and boost the transmission range. It possible to use up to 8 repeaters for each FLTA receiver.

Addressing Transmitters

Each wireless transmitter, repeater and FLTA control module/receiver needs to have unique address. Wireless transmitter address consists of two parts; SID (Sensor ID) and MID (Master ID). The transmitter address is configured using FLSEr service tool. MID is the address of FLTA control module/receiver. Typically MID is set to one in a single FLTA network.

Example (single network, two transmitters):

Sensor 1: TEFL Room Transmitter Address: SID = 1, MID = 1

Sensor 2: KLU-FL Address: SID = 2, MID =1

Master 1: FLTA Address: MID = 1

KLU-FL and TEFL have MID address 1. This means that they are transmitting measurements to the FLTA that has been addressed with the same MID.

Example (two networks, two transmitters):

Sensor 1: KLU-FL Address: SID = 1, MID =1

Sensor 2: KLU-FL Address: SID = 1, MID =2

Master 1: FLTA Address: MID = 1

Master 2: FLTA Address: MID = 2

Sensor 1 transmits the measurements to Master 1 (FLTA), and Sensor 2 transmits the measurements to Master 2. Although the both sensors have the same SID this will not cause problems as MID is different.

Operational Diagram

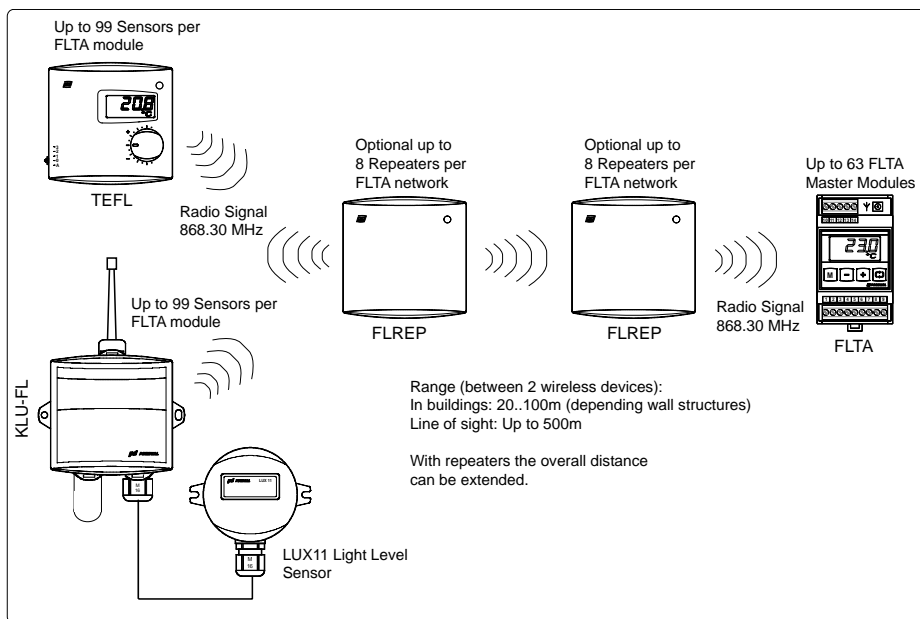

LED Operation

KLU-FL has LED on its printed circuit board. In normal operation the LED indicates on the error conditions:-

- 1 flash / 2 seconds low battery alarm and network error
- 1 flash / 4 seconds low battery alarm
- 1 flash / 8 seconds network error (transmission failure)

LED is also used to indicate the selection of the transmission interval

- 6 second 1 flash
- 1 min 2 flashes
- 5 min 3 flashes
- 15 min 4 flashes
- 30 min 5 flashes

Accessories for HDH

Model	Description
FLSER	Wireless Service Tool for Addressing, Signal Strength Testing and Repeater Emulation
FLTA	Wireless Control Module / Receiver Unit with Modbus and 8 Analogue Outputs
FLAN	Antennae for FLTA
FLREP	Wireless Repeater to Extend Transmission Distance