

Magictime Digital Chronostat

This electronic chronostat is suitable for a reliable and accurate temperature regulation in commercial and industrial premises as well as in home installations. The chronostat has built in comprehensive weekly and daily programming capability that assures flexibility to both heating and cooling applications. Optimiser program switches heating optimally ON providing ultimate comfort. Low temperature frost protection feature protects the building during the long heating off periods.



FEATURES

- Unique version: both Daily and Weekly Programming
- Optimiser feature
- 2 batteries AA type power supply
- 2 level room temperature regulation: Comfort and Reduced o Guided programming
- Manual work feature
- 'Heating' or 'Cooling' mode with front panel selection
- Off position with adjustable antifreeze function
- Room temperature or current time readout
- Fixing with distance between holes 60 mm or 83 mm (3 mod. junction boxes)

Model Types	Model	Description
	TCPCD1BI	TCPCD1BI Magictime Digital Chronostat
Technical Data	Power Supply	2 x 1.5V= (AA type) alkaline
	Batteries Duration	~ 1 year
	Regulation Range	Comfort: 10°C .. 30°C Reduced: 10°C .. 30°C
	Temperature Sampling	Approx. every 3 minutes
	Differential	0.4°C (asymmetric.: example. 20.0°C off 19.6°C on - heating mode - 20.0°C off 20.4°C on - cooling mode)
	Sensor Type	NTC 100kOhm @ 25°C internal
	Accuracy	± 1°C
	Resolution	Readout: 0.1°C; Set-point: 0.2°C
	Contacts Rating	(1) A @ 250V~ SPST (N.O.)
	Storage Temperature	-10°C .. +50°C
	Operating Temperature	0°C .. 40°C
	Protection Class	IP30
	Humidity Limits	20% .. 80% rH (non condensing)
	Enclosure	Material: ABS V0 self-extinguishing
Colour	Cover: Signal white (RAL 9003) Base color: Anthracite grey (RAL 7016)	
Size	133W x 87H x 32D mm	

User Instructions

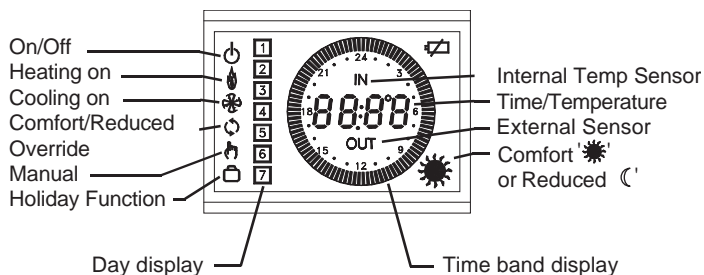

Initial Setup

At initial setup follow these steps:
 Insert batteries as indicated and reset the chronostat with a small tip (such as pen) through the hole (7) as shown in Figure 2.
 6 buttons are present under the plastic door covering the batteries

- 'P' programming
- day, hour & minutes regulation
- 'OK' confirmation (5 – see Figure 6)
- forward (4 – see Figure 6)
- back (6 – see Figure 6)
- 'reset' accessible through hole (7) for internal circuit and program test

Three buttons are on the front, close to the display:

(manual) (temperature-time) (On/Off).

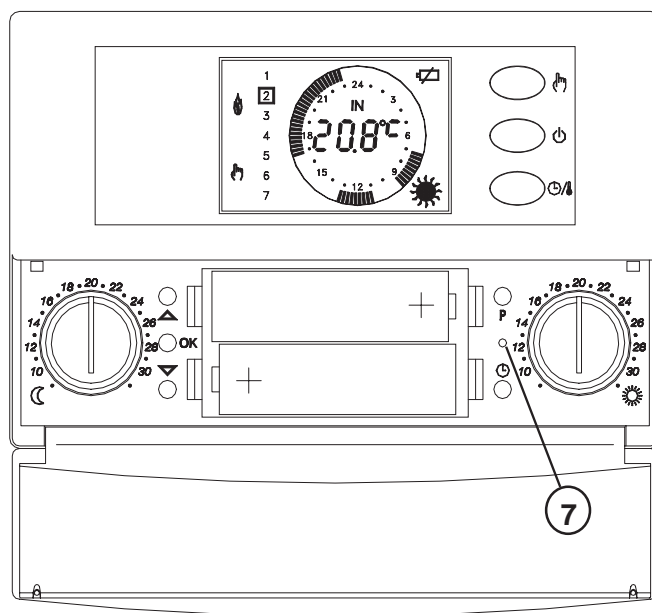

Fig. 2

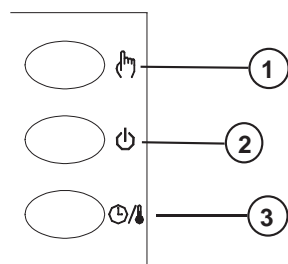

Fig. 5

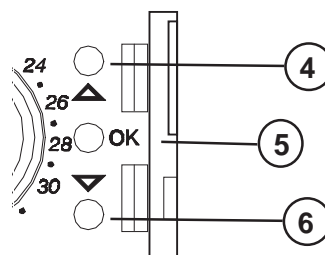

Fig. 6

Clock Functions

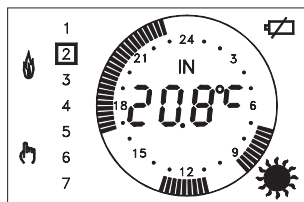

Fig. 7

In order to set the clock of MAGICTIME (Fig. 7), follow these steps:

1. Open the plastic door covering batteries.
2. Press the clock button for at least 2 seconds.
3. Set the day with buttons '▲' or '▼'.
4. Confirm with button 'OK'.
5. Adjust current hour with buttons '▲' or '▼'.
6. Confirm with button 'OK'.
7. Adjust current minutes with buttons '▲' or '▼'.
8. Confirm with button 'OK'.

After 1 minute of inactivity on buttons, the chronostat will automatically exit the programming mode.

Heating/Cooling Selection

Pressing for at least 3 seconds the button '▼' (back) the Heating mode is selected and the symbol '🔥' appears.

Pressing for 3 seconds the button '▲' (forward), the Cooling mode is selected and the symbol '❄️' is displayed.

When batteries are replaced, the heating or cooling mode must be reprogrammed.

Programming Mode

The selection of the programming mode is made through the buttons '▲' (forward), '▼' (back), 'OK' (confirmation) and 'P' (programming).

To enter the programming mode the button 'P' must be pressed for at least 2 seconds: the display will show one of the following day combination:

- a) 1 2 3 4 5 Monday .. Friday +
6 7 Saturday .. Sunday
- b) 1 2 3 4 5 6 Monday .. Saturday +
7 Sunday
- c) 1 2 3 4 5 6 7 Monday .. Sunday
- d) 📅 luggage
(holiday function)
- e) 1 Monday day by day
2 Tuesday program
3 Wednesday J
4 Thursday
5 Friday
6 Saturday
7 Sunday

Press '▲' (forward) or '▼' (back) to change and 'OK' to confirm.

Pressing the 'P' button, will exit the programming mode.

After the confirmation of the day combination (with 'OK' button), a time cycles combination will flash on the display.

Through the 4 buttons '▲' (forward), '▼' (back), 'OK' (confirmation) and 'P' (programming), combinations can be selected: (from 1 per day minimum, to 4 per day maximum):

- a) 1 time cycle: 06:00 23:00
- b) 2 time cycles: 06:00 08:00
17:00 23:00
- c) 3 time cycles: 06:00 08:00
11:00 13:00
17:00 23:00
- d) 4 time cycles: 06:00 08:00
11:00 13:00
17:00 19:00
21:00 23:00

Temperature Setting

Through the two knobs (Fig. 3 and 4) '☾' (moon) and '☀' (sun) it is possible to adjust the 'Economy' and the 'Comfort' temperatures as set by the program.

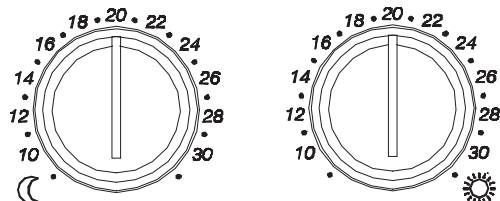

Fig. 3

Fig. 4

Holiday Program

If the 'Holiday' combination is selected, the symbol '🧳' (luggage) will flash: pressing the 'OK' button (confirmation) it will be possible to set with buttons '▲' (forward) and '▼' (back) the number of hours (h. 00..95). Once reached the max hours number the display will automatically switch to days indication (d. 04..99). During this period the heating or cooling will be off (only the antifreeze function will remain active). When the antifreeze program is activated, the current hour or day will be included: in this case (but only in heating mode), the antifreeze temperature is displayed and can be modified with the buttons '▲' (forward) or '▼' (back).

Manual Mode

Pressing the 'manual' button (1) the chronostat can be forced to operate in a different mode from the one set by the current program.

Pressing it once an 'override' function is activated: the temperature is regulated according to the opposite level (Comfort in place of Economy or vice versa) with respect to the one currently selected by the program, until the next action of the program occurs. In this way the next action is 'anticipated' by this 'override' function.

The chronostat, will return in normal mode on the next action, the symbols '👤' (manual) and '🔄' (override) will be on and the time cycles are visible. In this mode the room temperature is still displayed.

Pressing twice the manual button, the chronostat will be forced in continuous 'Comfort' temperature mode, while pressing once again it will be forced in continuous 'Economy' temperature mode; symbols '👤' (manual), '☀' (sun) and '☾' moon) will be on and the room temperature will be displayed. If the manual button is pressed once again, the chronostat returns in normal mode.

Time / Temperature Display

By pressing the '🕒' button (3) you can display the current time; in case an external sensor is wired to the relevant terminals by repeatedly pressing the same button you can even display the internal (the label 'IN' appears on the display) or external temperature (the label 'OUT' appears).

In case no external sensor is wired to the terminals, the regulation is made with respect to the internal one.

On the other hand when an external sensor is wired, you can choose the reference sensor (internal or external) for the regulation by moving the relevant dip switch located on the thermostat back. See section "Additional functions"

Turn-on / Turn-off

The chronostat can be turned off by pressing the '🔌' button (2) which (only for heating mode) will force the regulation at an adjustable temperature level between - 5°C e 25°C through the '▼' (forward) and '▲' (back).

Additional Functions

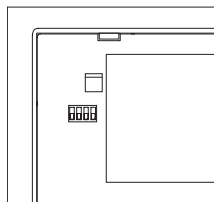

Fig. 8

The presence of 4 dip switches located on the thermostat back (Fig. 8) gives access to some additional functions.

The thermostat is factory set with the dip switches in the following configuration:



4 3 2 1

- 1. Reserved:
keep in lower position.
- 2. Optimization enabled.
Optimization disabled.
- 3. Time proportional regulation enabled.
Time proportional regulation disabled.
- 4. Regulation through external sensor.
Regulation with internal sensor.

1. Reserved

This dip switch must be kept in the lower position.

2. Optimization

The optimization function gives the chance to turn the heating on with a time advance with respect to the programmed time so that the user will actually have the desired temperature (that is the set one) at the programmed time.

The thermostat measures the time the environment needs to get to the desired temperature and, consequently anticipates the programmed turn on by the time needed to get to this goal.

The optimization can be activated by moving a dip switch located on the thermostat back: the time advance is calculated with respect to the mean temperature gradient in the last 24 hours, with a maximum of 60 minutes time advance.

3. Time proportional operation

By moving this dip switch located on the rear of the thermostat the user can switch between the standard work (on-off with an asymmetrical 0.4°C differential) and a time proportional work with a band and intervention times that fit the most of civil environments.

4. Internal - External sensor selection

By moving this dip switch located on the rear of the thermostat the user can select as a reference sensor for the regulation either the internal sensor or the external (remote) one.

Available Accessories

The following accessories are available as options:

- Remote telephone interface (Fig. 9), code: ACC PH INF W (junction box mount);

- Remote sensor, code: STL OTS A150.

Through an interface wired to the telephone line the user can remotely drive a switching contact which, in turn, can force the thermostat to the Comfort mode, whichever the current state is. When the driving contact in the interface is released, the thermostat returns to the normal work according to the current settings and temperature. When the telephone interface is activated the hand symbol (**manual**) flashes on the display.

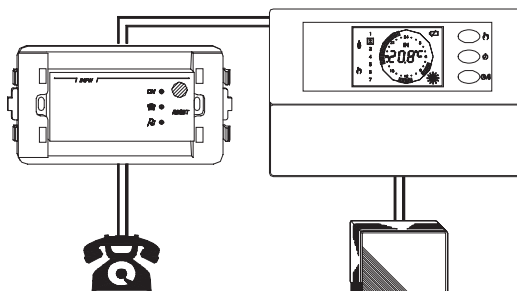

Fig. 9

Installation – Wall Mounting

The adapting plate (Fig. 1), can be fixed using the screws and relevant shells included in the box or, alternatively, directly on the wall or on 3 modules junction boxes; on the plate will then be hooked the chronostat body, carrying the terminals for electrical wirings protected by a plastic back. In any case, in order to grant the electrical safety, it is mandatory to screw the chronostat body to the wall through the two screws supplied which must be mounted in the battery holder. The chronostat must be located about 1.5 m above the floor level, far from heat sources, doors and windows.

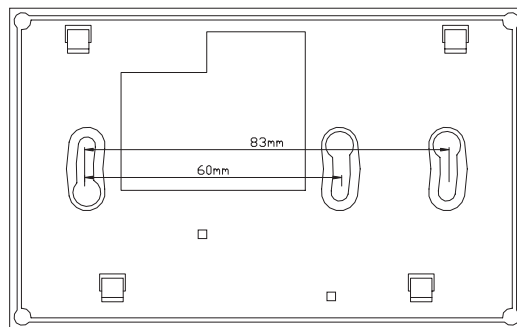

Fig. 1

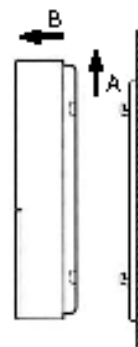
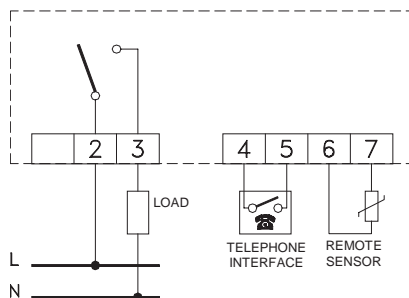

Fig. 10

Wiring Diagram

In order to make electrical wirings connect to the following terminals:
 - 2 and 3: heater or cooler according to the drawing
 - 4 and 5: telephone interface (optional) for remote control of the chronostat
 - 6 and 7: remote sensor (optional).



Batteries replacement

When the display shows the battery symbol, batteries must be replaced. In order to perform this operation proceed as:
 1. Open the plastic door covering the batteries.
 2. Remove old batteries with the help of a small tool.
 3. Insert the new batteries which must be 1.5V AA alkaline.
 4. If the chronostat seems not to operate well, perform a reset through button (7).

WARNING !

- To adjust properly room temperature, install the thermostat far from heat sources, air streams or particularly cold walls (thermal bridges). When a remote sensor is used in conjunction with the thermostat, then this note is to be applied to the remote sensor itself.
- For remote version all wirings must be made using wires with 1.5 mm² minimum cross-section and wiring must be no longer than 25m. Do not use same conduit for signal wires and mains.
- The appliance must be wired to the electric mains through a switch capable of disconnecting all phases compliant to the current safety standards and with a contact separation of at least 3 mm in all phases.
- Installation and electrical wiring of this appliance must be made by qualified technicians and in compliance with the local safety standards.
- Before wiring the appliance be sure to switch the mains power off.

Notes: In the view of a constant development of their products, the manufacturer reserves the right for changing technical data and features without prior notice. The consumer is guaranteed against any lack of conformity for 24 months from the time of delivery, according to the European Directive 1999/44/EC. The full text of guarantee is available on request from the seller.